

PKS-PRO-AEA-EC-08 - Servo System



FEATURES

- Updates 1000 Inputs/Outputs of Information
- Rated Torque of 338 oz-in
- Power Ratings up to 750 Watts
- Open Network Based on Ethernet
- 17-bit Absolute Encoder
- Maximum Speed of 4,500 RPM
- Supports Topologies - Line, Tree, and Star Type
- Brake Option Available
- CE Certified



DESCRIPTION

The PKS-PRO-AEA-EC-08 EtherCAT Servo System includes a 750 Watt EMJ-08 Servo Motor operated by the PRONET-08AEA-EC EtherCAT Servo Drive. These packages are ideal for easy start-ups, convenience, and performance. The Servo Motors included in these packages provide up to 338 oz-in of Rated Torque. The PRONET-08AEA-EC Drive offers current forward-feedback control, acceleration forward-feedback control, speed viewer, Ethernet networking, and inertia viewer; providing for improved response performance. Each system includes a 5m Motor Power Cable and a 5m Encoder Cable.

Item	Rated Voltage (VAC)	Rated Speed (RPM)	Rated Torque (oz-in)	Rated Current (Arms)	Inertia (oz-in-sec ²)	Torque Constant KT (oz-in/A)	Resistance (ohms)	Inductance (mH)	Brake (24VDC)	Motor Length (mm)	Shaft Diameter (mm)
PKS-PRO-AEA-EC-08-JP22	200	3000	338	4	0.01911	86.8	2	19.25	No	151	19
PKS-PRO-AEA-EC-08-JP24	200	3000	338	4	0.02081	86.8	2	19.25	Yes	194	19

ORDERING INFORMATION

PKS-PRO-AEA-EC-08-JP22

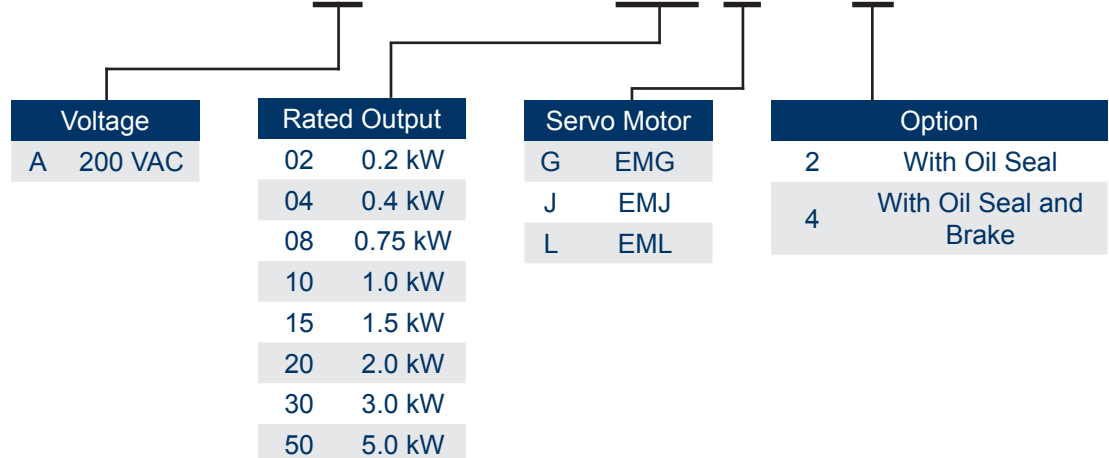

L011573

EMJ-08 Motor Specifications



FEATURES

- 220 VAC
- **Rated Torque of 338 oz-in**
- **750 Watt Power Rating**
- **Rated Speed 3000 RPM**
- **Maximum Speed 4500 RPM**
- **Peak Torque up to 300% of Rated Torque**
- **Peak Current up to 300% of Rated Current**
- **131,072 PPR Absolute Encoder Attached**
- **Enclosed and Self-Cooled**
- **Brake Option Available**
- **CE Certified**



SPECIFICATIONS

Model #	Rated Torque (oz-in)	Rated Power (Watts)	Rated Speed (RPM)	Max Speed (RPM)	Rated Current (A rms)	Brake (24VDC)	Inertia (oz-in-sec ²)	Torque Constant K _T (oz-in/A)	Resistance (ohms)	Inductance (mH)	Length (mm)	Weight (lbs)
EMJ-08ASB22	338	750	3000	4500	4	No	0.01911	86.8	2	19.25	151	6.52
EMJ-08ASB24	338	750	3000	4500	4	Yes	0.02081	86.8	2	19.25	194	8.06

TORQUE CURVE

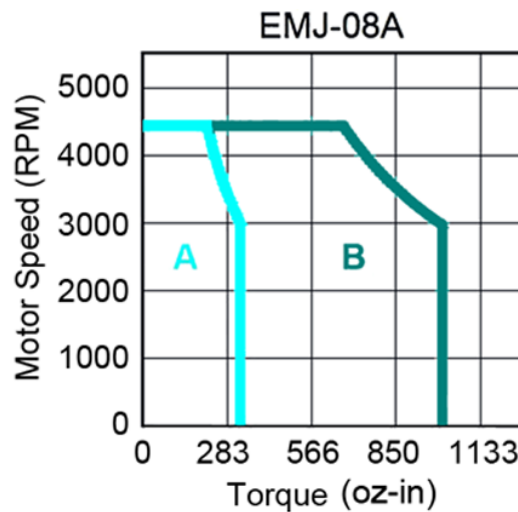

A: Continuous Working Area
 B: Repeatedly Working Area

Unit: mm

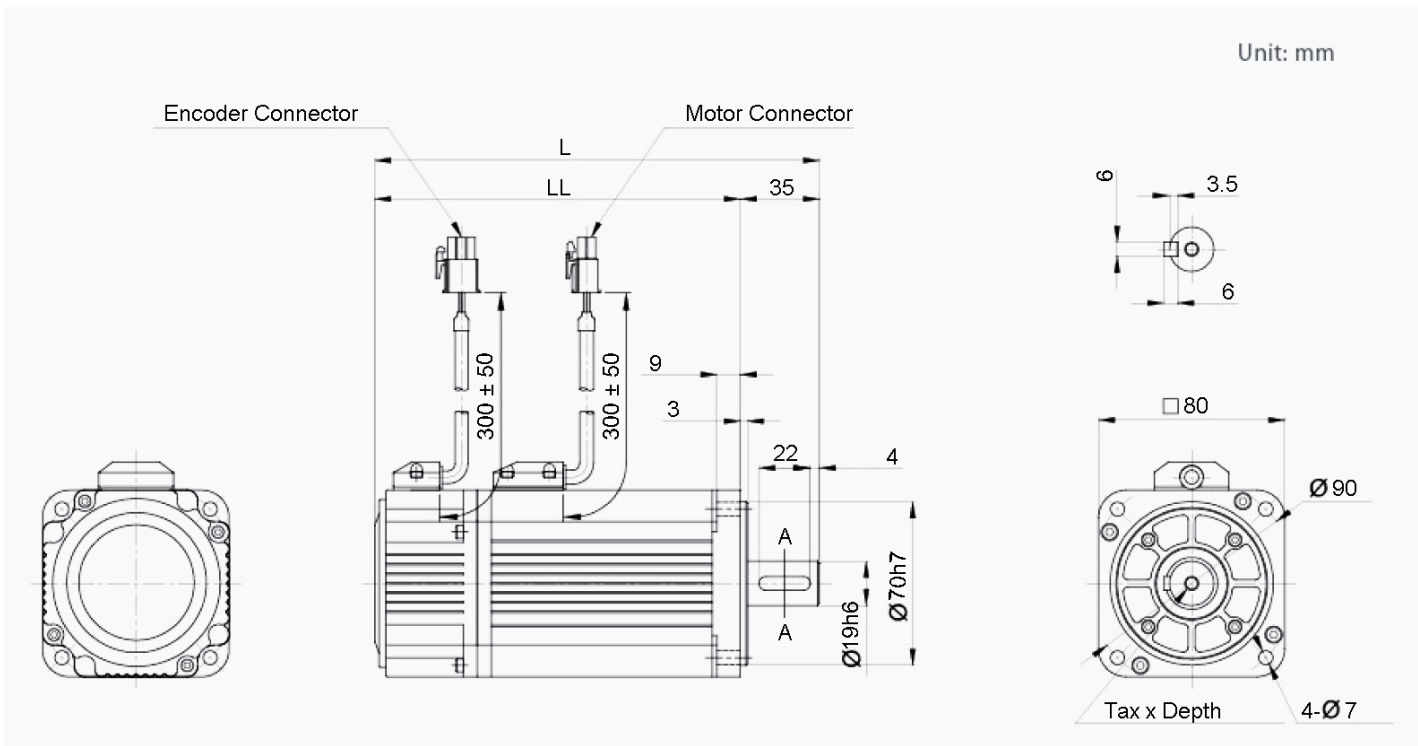

Model #	L	LL
EMJ-08ASB22	186	151
EMJ-08ASB24	229	194

Note: All Dimensions in millimeters

Note: the EMJ-08ASB24 are Servo Motors with holding brakes.

Encoder Connector Specification:

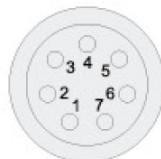

Pin No.	Signal
1	S+
2	S-
3	BAT+
4	BAT-
5	PG5V
6	PG0V
7	FG

Motor Connector Specification:

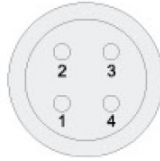

Pin No.	Signal
1	U
2	V
3	W
4	FG

Brake Connector Specification:



Pin No.	Signal
1	B1
2	B2

Power Requirement: 220VAC	Vibration: 49 m/s ²	Running Air Pressure: 86 to 106 kPa
Insulation Class: F	Ambient Temperature: 20% to 80% RH	Insulation Voltage Endurance: AC 1800C, 50Hz, 1 min
Ambient Temperature: 0°C to 40°C	Running Humidity: Not More Than 90%, Under 25°C	Insulation Impedance: Not Less Than 50M Under Normal Conditions
Running Temperature: -25°C to 40°C		

Compatible Driver

Part Number	Description
PRONET-08AEA-EC	Servo Driver



Compatible Cables

Part Number	Description
PDM-JE18-05	Power Cable
PAP-JE24-05	Encoder Cable



PRONET-08AEA-EC Driver Specifications



FEATURES

- Power Rating of 750 Watts
- 100 BASE-TXI Twisted-Pair Wire, 100 BASE-FX Fiber, or LVDS (Low Voltage Differential Signaling)
- Supports Topologies - Line Type, Tree Type and Star Type
- Open Network Based on Ethernet
- Capable of Updating the Information of 1000 I/O
- Exchange of Frame as Big as 1486 Bytes



DIMENSIONS

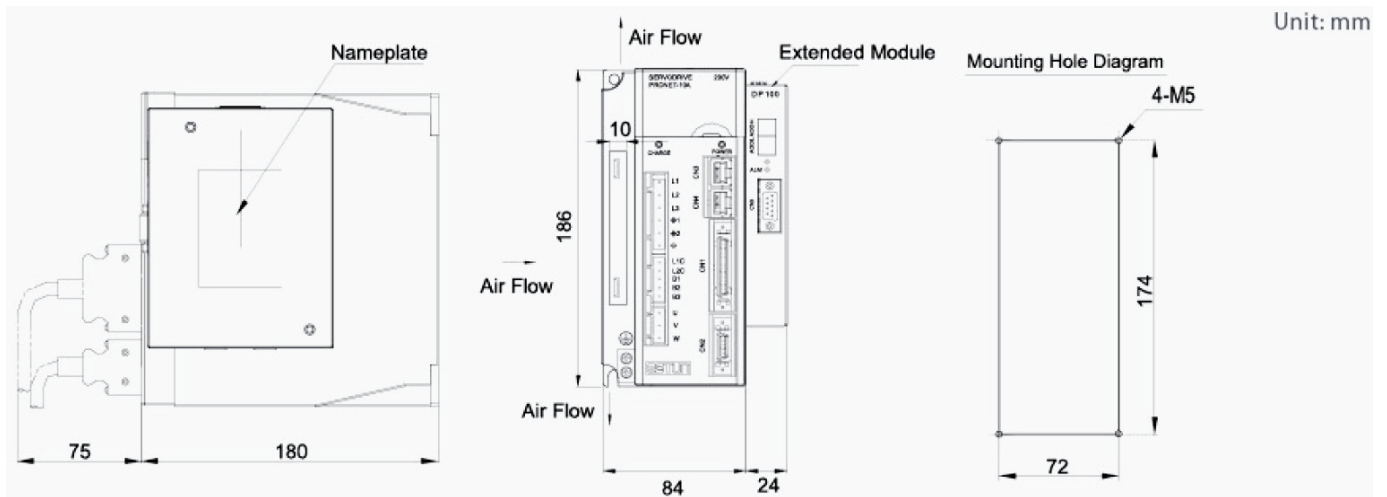

Item	Rated Power (Watts)	Rated Voltage	Drive Control Capabilities	COMM	I/O Signals
PRONET-08AEA-EC	750	200VAC	Position, Speed, Torque	EtherCAT	5 Inputs 3 Outputs

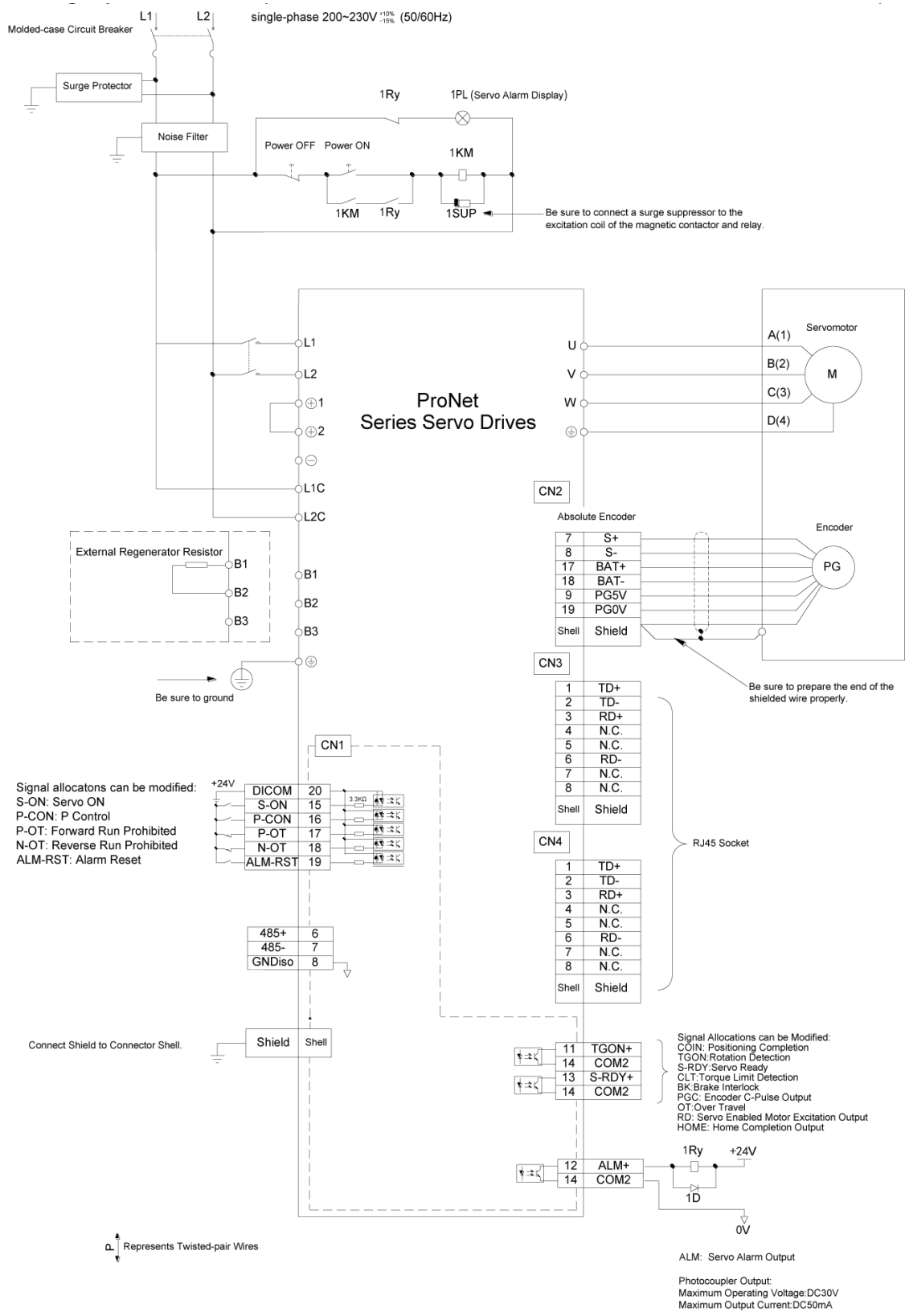

Compatible Drivers

Part Number	Description
PRONET-08AEA-EC	Servo Driver



Compatible Motors

Part Number	Description
EMJ-08ASB22	Servo Motor
EMJ-08ASB24	Servo Motor



Compatible Cables

Part Number	Description
PAP-JE24-05	Encoder Cable
PDM-JE18-05	Power Cable

